

PowerModule™ PM3000W

The Standard for Wind Power Converter Technology

Developed specifically for wind power applications, the PowerModule™ PM3000W from American Superconductor (AMSC) introduces a new era in wind power conversion with a scalable, double conversion architecture that uses easily mountable mono-frame construction for a common building block.



Advanced Grid Compatibility

The PM3000W is an intelligent and highly integrated power converter which meets the demanding needs of wind power applications and features advanced grid compatibility control and a compact package design that yields a very high power density of up to 130 W/in.³ (7.9 W/cm³).

Double Conversion Architecture

The double conversion architecture includes a common laminated DC bus design with dynamic control, state-of-the-art ruggedized (thermally and mechanically enhanced) IGBTs, control algorithms and liquid cooling. Two dual-DSP embedded controllers (one for each power conversion process) allow implementation of two separate control functions with independent software for each. Additionally, OEM proprietary algorithms can reside in one, or two, of the DSPs.

Wind power specific interface and application modules offer unmatched versatility —making the PM3000W converter the best solution for wind power applications.

Benefits

- **Developed for wind power applications**
 - Wind power specific interface and application modules
 - Double conversion architecture
 - Common laminated DC Bus with dynamic control
 - Mono-frame construction
 - Advanced grid compatibility
 - Universal generator connectivity
 - Supports LVRT (Low Voltage Ride Through)
 - High power density
- **Rapid product development**
 - Rapid software and parameter configuration
 - Programming can be done remotely
- **Easy to use**
 - Remote communication
 - Self-protected
 - Slide mounts
 - Ground fault protection
 - Fault annunciation
 - Product protection against malfunction
- **Scalable design**
 - Standard building block
 - Bi-directional functionality
 - Parallel operation

PowerModule PM3000W Architecture

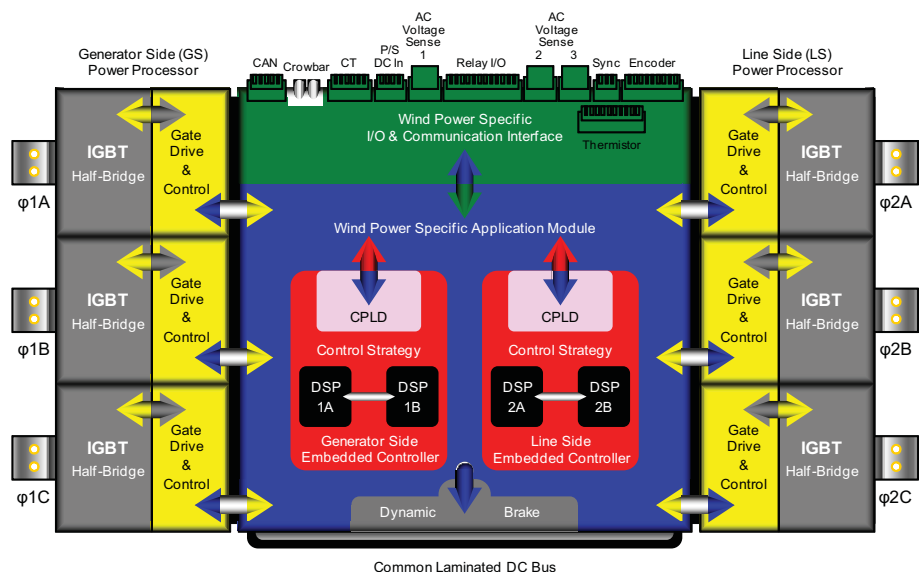

Multiple PM3000W converters can be configured in parallel —enabling higher power-rated converters. Example shown is configured to support AC-AC power conversion.



Specifications

Nominal AC Voltage:	690 VAC		
Nominal DC Bus Voltage:	1150 VDC		
Max. Transient DC Bus Voltage:	1400 VDC		
PWM Switching Frequency:	3 kHz		
Max. Continuous AC Phase Current:	750A		
Nominal Frequency:	50 Hz/60 Hz		
Overload:	115% for 10 seconds every 60 seconds		
Voltage Imbalance Tolerance:	5% continuous, 10% transient (contact factory for higher values)		
DC Bus Protection:	Integral dynamic brake		
Control:	2 dual-DSP embedded controllers with wind power specific application modules		
Communication:	Real-time CAN (1 Mbps) over galvanic link		
I/O Interface:	<ul style="list-style-type: none"> CAN communications Power supply DC input Incremental encoder 	<ul style="list-style-type: none"> Crowbar (fiber optic - duplex) AC voltage feedbacks (x3) Temp. sensors - thermistors (x9) 	<ul style="list-style-type: none"> CT's (x3) Relay I/O (x4) Sync signal
Control and Setup Parameters:	<ul style="list-style-type: none"> Voltage regulator gains Voltage limits 	<ul style="list-style-type: none"> Current regulator gains Current limits 	<ul style="list-style-type: none"> AC line frequency
Protection Features:	<ul style="list-style-type: none"> Over current Over/under voltage Over/under frequency Ground fault 	<ul style="list-style-type: none"> DC bus over/under voltage Ambient over/under temperature Heatsink over/under temperature Thermistor over/under temperature (x9) 	<ul style="list-style-type: none"> Loss of communications Contactors monitors (2x) IGBT de-saturation
Diagnostic Variables:	<ul style="list-style-type: none"> Output current Output voltage Line frequency 	<ul style="list-style-type: none"> DC bus voltage Ambient temperature Heatsink temperature 	<ul style="list-style-type: none"> All control variables
Ambient Operating Temperature:	-25°C to 65°C (-13°F to 149°F)		
Liquid-cooled Inlet Temperature:	-25°C to 50°C (-13°F to 122°F), 5 gpm - 10 gpm (18.9 L/min - 37.9 L/min)		
Storage Temperature:	-40°C to 85°C (-40°F to 185°F)		
Humidity:	0% to 95% RH non-condensing		

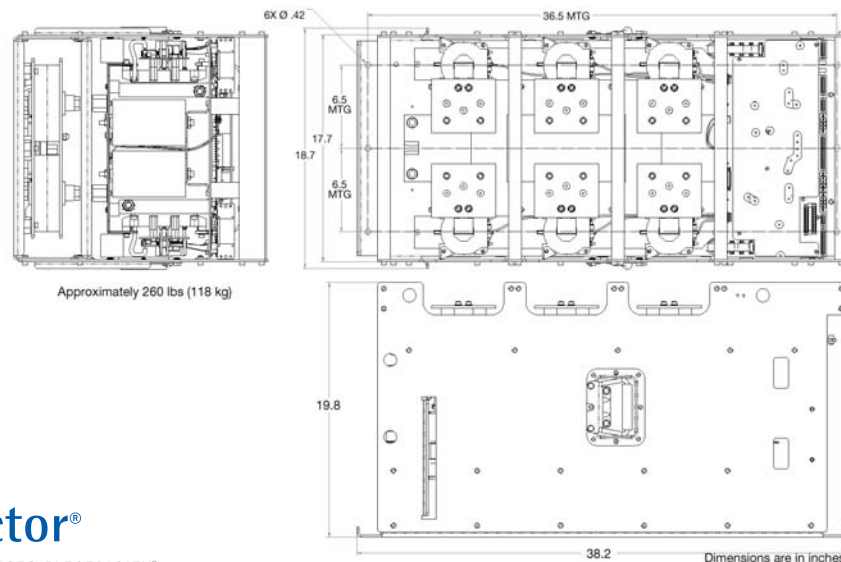

REVOLUTIONIZING THE WAY THE WORLD USES ELECTRICITY®

Visit our website at www.amsc.com or email us at sales@amsc.com

15775 W. Schaefer Court
New Berlin, WI 53151
ph +1 262.901.6000
fx +1 262.901.0100

Gartenweg 2
Issum 47661 Germany
ph +49 2835 790371
fx +49 2835 790372

Schleppeplatz 5
9020 Klagenfurt
Austria
ph +43 463 444604 0
fx +43 463 444604 44

Tower B, #1805-1806,
Wanda Plaza,
No. 93 Jianguo Road,
Chaoyang District, Beijing,
100022 P.R.C.
ph +86 10 5820 5757
fx +86 10 5820 5768

Suntec Tower Three
8 Temasek Boulevard
Singapore 038988
ph +65 68663 629
fx +65 68863 636